

The Banderlog Diverter Power Relay

What is the *Banderlog Diverter Power Relay*?

Jet boat hydraulic diverter systems draw their power, for running the hydraulic pump and valves, through the ignition and the trim switches. These switches are typically mounted at the far end of the boat from the pump itself. Whereas the battery is usually mounted near the trim pump, so distances are doubled. The *Banderlog Diverter Power Relay* changes all this. Using the *Power Relay*, only a small signal current is pulled through the ignition and trim switches. The power to run the pump and valving is brought directly from the battery to the pump.

Basic installation.

The control wires on the *Power Relay* are about 12" long. Take this into consideration when choosing your mounting location. The *Power Relay* should be mounted in dry place near the hydraulic trim pump. Also, the shorter that the power wire run is, the better.

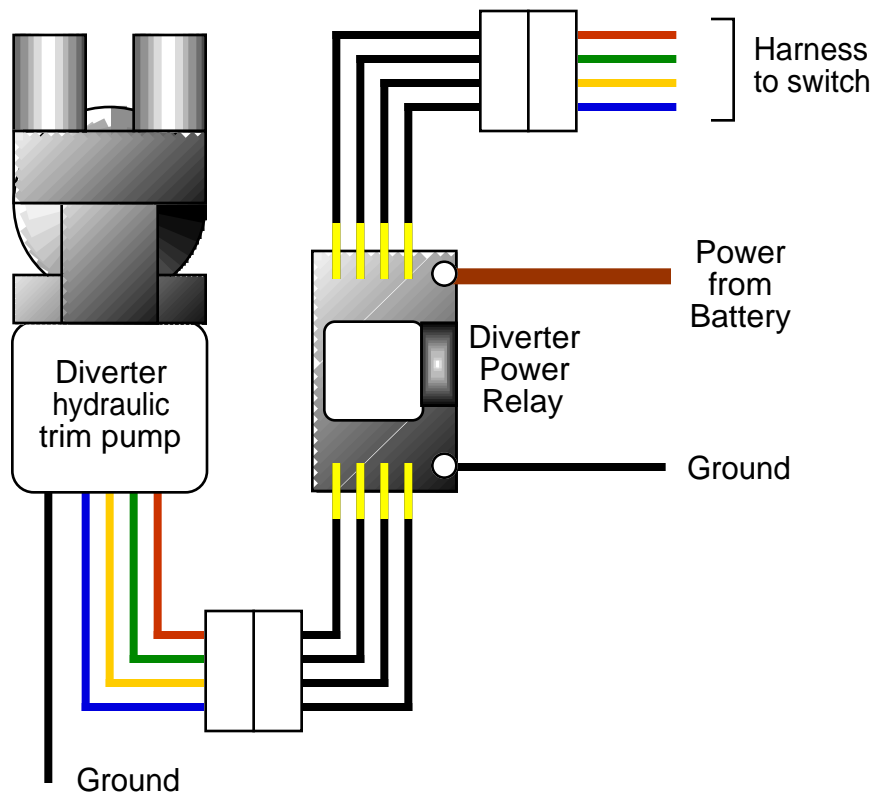

Overview of the basic installation.

Once the *Power Relay* is mounted, we can turn our attention to hooking it up. Disconnect the switch harness from the hydraulic trim pump. Plug both ends of this harness into the control wire plugs of the *Power Relay*.

NOTE : If the control wires coming out of the *Power Relay* are allowed to flex, they can fatigue and break at the point that they exit the box. Therefore, these wires must be

anchored down. To accomplish this, wire anchors, tie wraps and screws have been supplied with the *Power Relay*. Use these to secure the control wires.

The *Power Relay* needs 12V power and ground to operate. Power is supplied through the larger red wire, ground is through the smaller black wire. The Power wire should be hooked directly to the battery, or to the battery selector switch if one is being used. The ground wire should be hooked to the nearest suitable ground. The engine block would be an example of a suitable ground. Heat shrink tubing and wire ends have been supplied to help with a tidy installation.

One last thing to think about would be the ground for the hydraulic trim pump itself. It does no good to feed the pump with plenty of battery current, if it can't pass it through to ground. Make sure that the ground wire on the pump is as direct as possible to a good solid ground.

That's it. Double check everything and you're done!

More information.

The built in fuse.

The *Power Relay* incorporates a built in fuse. This fuse takes the place of the one supplied with the original hydraulic trim pump wiring harness. It is a 20 Amp automotive mini blade type fuse. A spare fuse has been supplied in case the first fuse fails. If more fuses are needed, they can be purchased from most automotive parts stores, or from *Banderlog*. But, if you need more than one extra, there is good chance that something is wrong in your wiring that should be looked into.

Switches and diodes.

The *Power Relay* works with the original wiring harness and switch that is supplied with the hydraulic diverter. It will work with aftermarket switches that have diodes built into them as well. It will also work with aftermarket switches *without diodes*. This is because the *Banderlog Diverter Power Relay* already incorporates the diodes in its design.



Aftermarket switch wiring without diodes.

If you would like to use an aftermarket switch without diodes, all you need to hook it to is power and the red & green wires from the switch harness. Red drives the diverter one way, green drives it the other. The yellow and blue wires are not used. The current draw for controlling the *Power Relay* is less than 0.5 Amps.

Questions : support@banderlog.com

Phone : (408) 779-5909